

Industrial

EU Stage IIIB / U.S. EPA Tier 4 Final / Japan 2014 (Tier 4 Final)
50 kW / 67 hp

Perkins®
SYNCRO

2.2 litre

The Perkins® Syncro 2.2 engine is the newest member of the highly successful Perkins 400 Series and has been designed to help our customers meet current emissions standards in Europe, North America and Japan.

The engine is a 4-cylinder, 2.2 litre, turbocharged aftercooled engine that offers supreme reliability, flexibility and an easy integration process.

Benefiting from a fully electronic fuel system, the engine further improves on the 400 Series reputation of excellent transient performance and low fuel consumption. It produces 50 kW (67 hp) and delivers excellent torque at low speeds, reduced owner and operating costs and low noise and harshness.

Commonality with other engines in the range has been built into this new engine, allowing for minimum machine change and reduced development costs for Perkins customers.

We have developed a reputation for designing and building reliable and durable engines suitable for the most demanding off-highway applications. An extensive range of options is on offer, making the 400 Series the complete solution for compact power needs.



Emissions

EU Stage IIIB / U.S. EPA Tier 4 Final / Japan 2014 (Tier 4 Final).

Specification	404F-E22TA	
Number of cylinders	4 vertical in-line	
Bore and stroke	84 x 100 mm	3.3 x 3.9 in
Displacement	2.2 litres	135 in ³
Aspiration	Turbocharged aftercooled	
Cycle	4 stroke	
Combustion system	Direct injection	
Compression ratio	18:1	
Rotation	Anti-clockwise, viewed on flywheel	
Total lubricating capacity	10.6 litres	2.8 US gal
Cooling system	Liquid	
Total coolant capacity	4.2 litres	1.1 US gal

www.perkins.com

Photographs are for illustrative purposes only and may not reflect final specification.
All information in this document is substantially correct at time of printing and may be altered subsequently.
Final weight and dimensions will depend on completed specification.

Publication No. PN3064B/02/17 Produced in England ©2017 Perkins Engines Company Limited

 **Perkins®**

THE HEART OF EVERY GREAT MACHINE

Industrial

EU Stage IIIB / U.S. EPA Tier 4 Final / Japan 2014 (Tier 4 Final)
50 kW / 67 hp

Perkins®
SYNCRO

2.2 litre

Features and benefits

Reliable, quiet, and durable power

- You are provided reliability, quiet operation, and many hours of productive life thanks to Perkins world-class manufacturing capability and processes, coupled with our proven core engine designs

Innovative design

- A simple, cost effective solution to meet current emissions standards
- Improved performance and reduced fuel consumption levels
- Flexibility in aftertreatment mounting
- Regeneration-free aftertreatment robust in all conditions
- Turbocharged and turbocharged aftercooled versions

Low cost of ownership

- Reduced oil consumption
- Easy maintenance and serviceability
- Improved fuel consumption
- Service-free aftertreatment system
- Regeneration-free aftertreatment system eliminates downtime
- 500-hour service intervals and two-year warranty as standard

Local support, global coverage

- Perkins recognise that the customer relationship is important to machine manufacturers and we can offer a range of flexible solutions to help provide appropriate support, either to the OEM's network or directly to the machine customer
- With highly trained Perkins distributors in thousands of communities in over 180 countries, you are never far away from expert product knowledge, genuine parts and a range of advanced diagnostic technology for keeping your engine in peak condition
- To find your local distributor: www.perkins.com/distributor

www.perkins.com

Photographs are for illustrative purposes only and may not reflect final specification.
All information in this document is substantially correct at time of printing and may be altered subsequently.
Final weight and dimensions will depend on completed specification.

Publication No. PN3064B/02/17 Produced in England ©2017 Perkins Engines Company Limited

 **Perkins®**

THE HEART OF EVERY GREAT MACHINE

Industrial

EU Stage IIIB / U.S. EPA Tier 4 Final / Japan 2014 (Tier 4 Final)
50 kW / 67 hp

Perkins®
SYNCRO

2.2 litre

Technical information

Core engine

- Multiple engine rating options
- Cast iron engine block
- SAE A PTO drive
- Flywheel and flywheel housing options
- Glow plug starting aid
- Engine mounting
- Block heater provision

Fuel system

- Electronic 2000 bar common rail fuel system
- Spin on fuel filter with water detector

Electrics

- Starter motor 12 volts
- Alternator 12 volts, 85 amp

Air system

- Turbocharged aftercooled configuration

Cooling system

- Belt driven coolant pump
- Cooling fan options
- Fan drive options

Lubrication system

- Oil sump options for various applications
- Spin on oil filter

Control system

- Electronic control module – chassis mounted
- Flexible and configurable software features and well supported SAE J1939 CAN bus enables highly integrated machines
- The wiring harness connectors and sensors are waterproof and designed to withstand harsh off-highway environments

Emissions control system

- Compact Diesel Oxidation Catalyst only aftertreatment system

Options group

An extensive range of options are available, enabling you to prepare a specification matched precisely to your needs.

www.perkins.com

Photographs are for illustrative purposes only and may not reflect final specification.
All information in this document is substantially correct at time of printing and may be altered subsequently.
Final weight and dimensions will depend on completed specification.

Publication No. PN3064B/02/17 Produced in England ©2017 Perkins Engines Company Limited

 **Perkins®**

THE HEART OF EVERY GREAT MACHINE

Industrial

EU Stage IIIB / U.S. EPA Tier 4 Final / Japan 2014 (Tier 4 Final)
50 kW / 67 hp

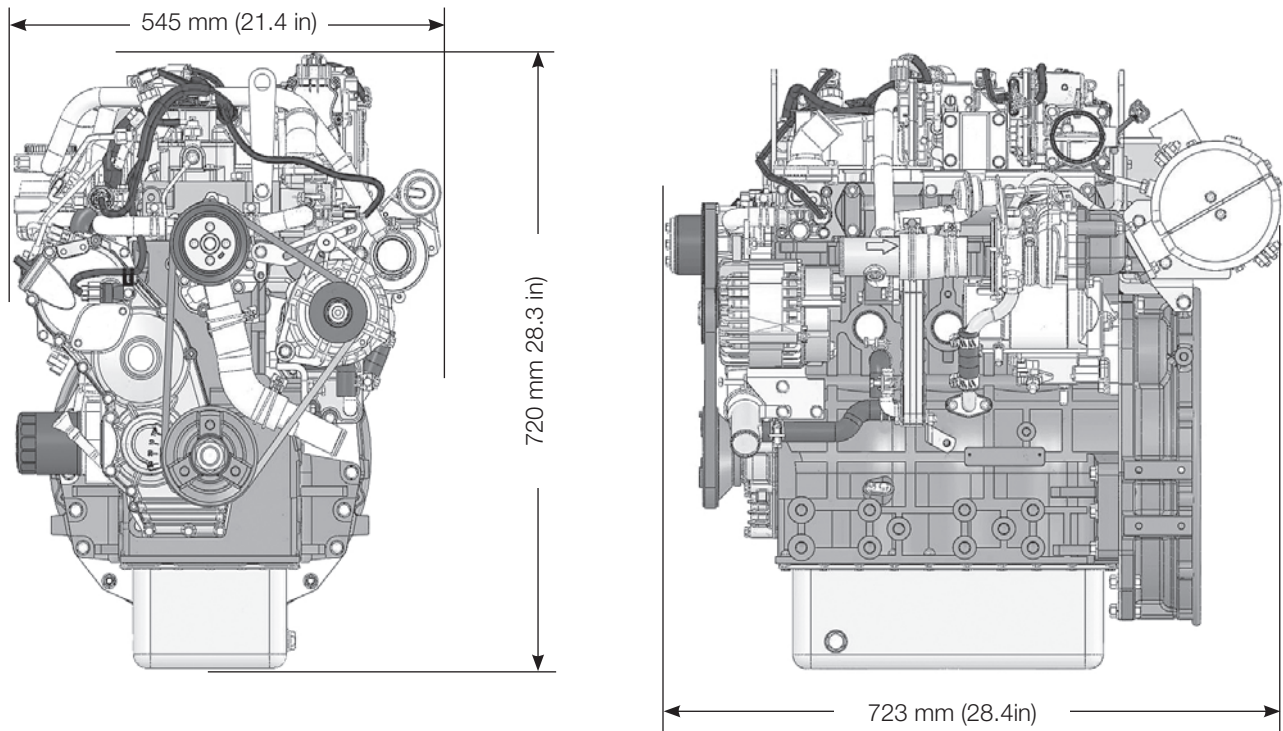

Engine package weights and dimensions – based on rear mount

Length (including fan)	723 mm	28.4 in
Width	545 mm	21.4 in
Height	720 mm	28.3 in
Weight (dry)	230 kg	507 lb

www.perkins.com

Photographs are for illustrative purposes only and may not reflect final specification.
All information in this document is substantially correct at time of printing and may be altered subsequently.
Final weight and dimensions will depend on completed specification.

Publication No. PN3064B/02/17 Produced in England ©2017 Perkins Engines Company Limited

Industrial

EU Stage IIIB / U.S. EPA Tier 4 Final / Japan 2014 (Tier 4 Final)
50 kW / 67 hp

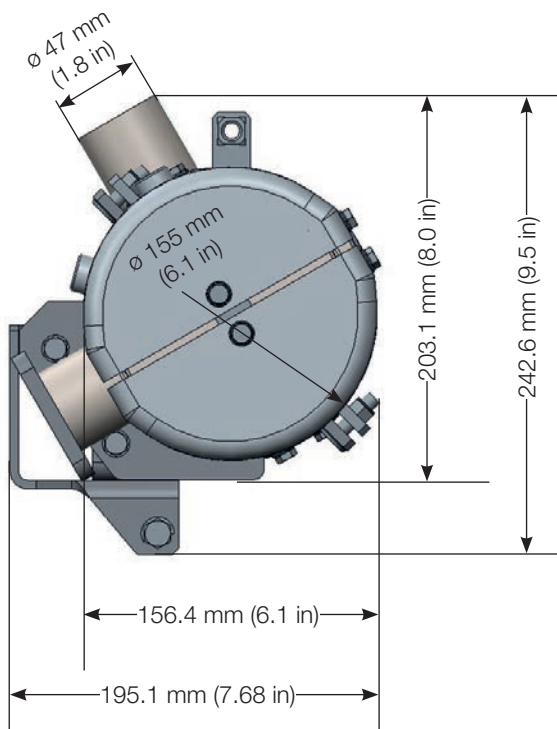
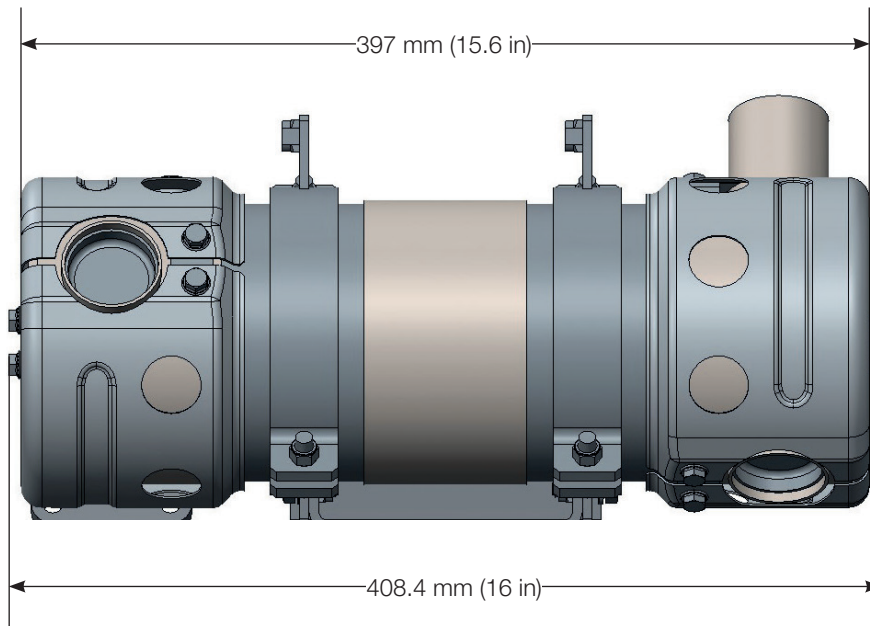

Aftertreatment

DOC – Diesel Oxidation Catalyst

Technology

The DOC technology provides customers with an aftertreatment solution that is as compact as possible. The aftertreatment is regeneration free, providing a seamless operation throughout the work cycle.

Service

Service-free operation.

Mounting

Mounted on-engine as standard. This will provide the simplest design and lowest total cost for the machine manufacturer.

An off-engine option will be offered for some machines.

Industrial

EU Stage IIIB / U.S. EPA Tier 4 Final / Japan 2014 (Tier 4 Final)
50 kW / 67 hp

2.2 litre

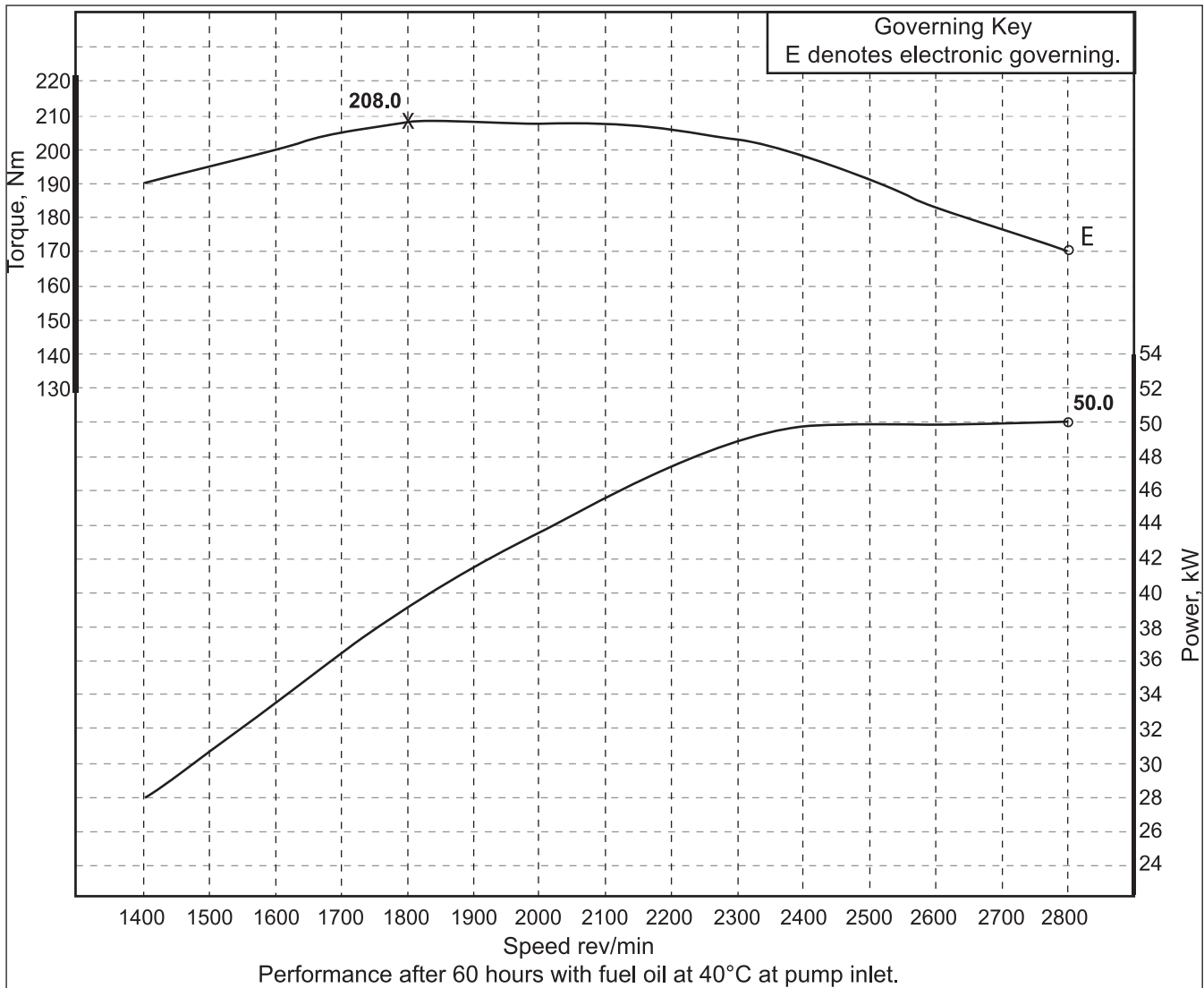

Speed rpm	Power kW	Power hp	Torque Nm	Torque lbf-ft	Rating type
2800	50	67	208	153.4	C

Rating definitions and conditions

IND-C (Intermittent) is the horsepower and speed capability of the engine, where maximum power and/or speed are cyclic (time at full load not to exceed 50%).

We have a selection of ratings to match differing machine requirements and will work with you to find the best power solution.

Rating Conditions for Diesel Engines – up to 7.1 litres are based on ISO/TR14396, inlet air standard conditions with a total barometric pressure of 100 kPa (29.5 in. Hg), with a vapour pressure of 1 kPa (0.295 in Hg) and 25°C (77°F). Performance is measured using fuel to specification EPA 2D 89.330-96 with a density of 0.845-0.850 kg/L @ 15°C (59°F) and fuel inlet temperature 40°C (104°F).

www.perkins.com

Photographs are for illustrative purposes only and may not reflect final specification.
All information in this document is substantially correct at time of printing and may be altered subsequently.
Final weight and dimensions will depend on completed specification.

Publication No. PN3064B/02/17 Produced in England ©2017 Perkins Engines Company Limited